



## LASER C-02 SERIES

Simple integrated design ensures smooth integration into your production line, intuitive user interface and Built-in wizard, which can significantly reduce operator training and make your master it quickly.

### Applications:

The C-02 series CO2 laser printers can print series number, batch number, bar code, QR code logo and flexible text on variety of products, such as IC chips, electronic components, plastic products, building material etc. Can be widely used in Food manufacturing, medical appliance, building materials, tubular products, et

### Features:

#### High quality products, reasonable price

Provide high quality at a reasonable price to make laser technology universal.

#### Precise design and flexible use

German technology and excellent component design ensure a reliable and high-quality system that can handle various application scenarios.

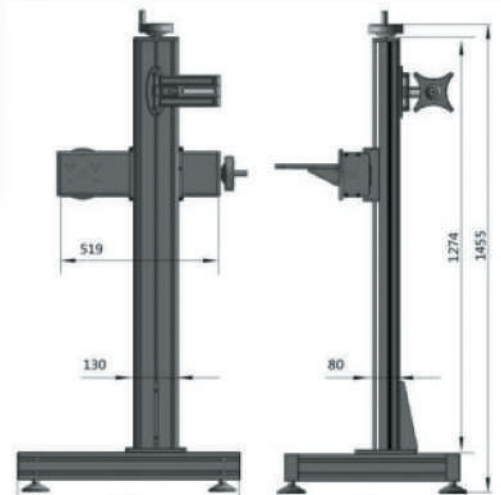
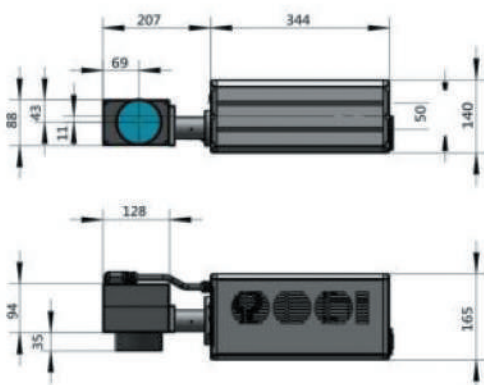

## Main Technical Parameters of CO2

Project	Parameter table	CO2 30 W	CO2 40 W	CO2 60 W
Characteristic	Machine Material	Al aluminum sandblasting oxidation		
	Laser	The service life is more than 20000 - 30000 hours		
	Laser Wavelength	1060 nm		
	Output Power	38W	43W	70W
	Marking Speed	12000 mm/s		
	Controler	10.2 Inch touch controller		
	Cooling System	Air Cooling		
Parameter	focus lens	145 mm		
	Minimum linewidth	0.03 mm		
	Repetition accuracy	0.01 mm		
	Marking Range	110 mm x110mm		
	Number of rows	Any line Within The Marking range		
	Production line Speed	130 m/min Depending on The Material		
Software	Multilingual	English, Spanish, German, Chinese, Russian, Arabic, etc		
	Jurisdiction	Multi User management authority		
	Operating System	linux system		
	Inkjet Mode	Static, Analog, Encoder		
	Reserved Signal	Start, print, status, finish, fault		
	Data Protection	With Power Failure Data Protection Energy		
	Monitor	Provide Overspeed Alarm Function		
	De Crossing	Automatic Removal of intersections		
	Coding Software	Single and double Machine code sending		
Support Type	Typeface	Chinese and English, Numbers, traditional, Etc		
	File Format	BMP/DXF/HPGL/JPEG/PLT		
	Bar Code	QR , CODE126, CODE128 , COD39		
Servicing Parameters	Power Supply	220V/50HZ		
	Power Consumption	800 W		
	Net Weight of Machine	38 KG		
	Overall Dimension	640mmX178mmX150mm		
Enviroment	Requirement	External Temperature 0C- 45C Humidity < 95		